



## Elite Force EF-180BV

80/75 Meter Linear Loaded Dipole Antenna

FREQUENCY COVERAGE: 3.500 - 4.000 MHz Min, Tunable (>60 kHz 2:1 VSWR points)  
Switchable CW & Phone with External Relay Box at Feedpoint

**Force 12, Inc.**

P.O. Box 1349 Paso Robles, CA 93447

(805) 227-1680 FAX (805) 227-1684 (800) 248-1985

The EF-180BV is an electrical quarterwave vertical for 80/75 meters. It has been shortened to about 35' and is mounted either on the ground, or elevated. The EF-180BV uses FORCE 12's Combined Inductive and Capacitive (C.I.C.) Linear Loading design, which provides the highest feed point impedance and broadest bandwidth of any shortened antenna to date. This results in a very low loss, highly efficient, shortened vertical antenna. The EF-180BV was re-designed in December, 1996 for larger cross-sectional profile on the high current area, stronger and less element deflection. The EF-180BV is now rated at 95 mph. The trunk sections are connected utilizing 14-20 bolts and the tip sections are riveted construction.

The antenna is shipped in sub-assemblies and each assembly section is appropriately identified. The antenna has already been pre-assembled at the factory, then disassembled for shipment; therefore, all the rivet holes are pre-drilled and will align exactly when the proper sections are matched. The antenna is insulated from the base section using solid fiberglass rod. It is fed directly with 50 ohm coax through either a 1:1 balun, or other means of a current balun (an RF choke would be quite large). The EF-180BV is matched using a helical hairpin (coil) attached across the feedpoint. At least two (2) full-length radials should be used.

The radials are the current return for the vertical antenna. For this purpose, the most efficient method is to have them elevated above the ground. This technique de-couples the radials from the ground. If the radials are on or in the ground, the number of radials will increase substantially in order to have an efficient radial system. Radials are not for the purpose of compensating for ground loss because of vertical polarization. Radials should be best when an electrical quarterwave long (i.e. 65') and when positioned equally around the antenna and elevated. Elevated radials can be as low as a foot or two.

The EF-180BV is extremely efficient and is only 54% of full size. This shortening results in a narrowing of the 2:1 VSWR bandwidth to about 60 kHz; however, the antenna is extremely efficient, with tests indicating the EF-180BV being less than 0.5dB down from a full size vertical within its operational bandwidth. The antenna is set to the desired operating frequency by moving the tuning jumper on each side of the antenna until the desired frequency is obtained. With the matching device in place, the VSWR will be lowest at this point. The input impedance at the feedpoint is obviously less than 50 ohms (about 14 ohms) and is stepped up to 50 ohms by using a hairpin match mounted across the feedpoint. This hairpin is in the form of a "helical hairpin", or coil, as a typical hairpin would be physically too large. The match to 50 ohms is adjusted by making the spacing on the coil wider or narrower. An optional relay switch box is available to allow for

moving around within the 80/75 meter band by switching in various small inductors at the base of the antenna.

The spreader that holds the linear loading is 8' long. It attaches to the provided thick-walled aluminum base tubing, which is below the base insulator of the antenna. If necessary, the spreader can be loosened in place so it can slide from one side to the other in order to reach the tuning jumpers on the linear loading. The EF-180BV is quite stable in winds, with the VSWR moving only slightly due to the entire antenna moving about. The most sensitive portion of the VSWR curve is on the sides, because this is a steep slope. Things get narrow on 80/75 meters. As a comparison to the width of the band, .500 MHz (3.500-4.000 MHz) represents 13.3% of the center frequency of 3.750 MHz. Twenty meters (20 mtrs), however, is .350 MHz wide and represents 2.47% of the center frequency of 14.175 MHz. This is why having antennas cover wide segments of 80/75 is so difficult. The easiest way to do it is to introduce a lot of loss, then it is simple, but not what we probably want!

The EF-180BV can be used later as a component in a 2, 3 or 4 element vertical array. FORCE 12 has phasing systems available. B). Please consult FORCE 12 for any questions in this area.

The markings have been left on the tubing and other markings made by the factory will quickly fade.

Please read all instructions carefully and also look at the pictures - they are truly worth a thousand words!

## ***Assembly Instructions:***

### NOTES:

- 1) Although the entire antenna has already been pre-assembled, it might be a good idea to double-check the measurements, especially on the elements. Please let us know if there are any discrepancies. Thanks.
- 2) When using the hand riveter, please be sure the smallest nozzle is in the tool. Sometimes with a larger nozzle, the mandrel of the rivet can get crooked within the tool, which can result in breaking the mandrel before the rivet is "popped." The smaller nozzle also makes a smooth finish on the rivet head.

### Tools required:

- A. Wrenches or ratchets, used for attaching the elements to the boom and the boom to the mast.
  1. 7/16"
  2. 1/2"
  3. 9/16"
- B. A 3/8" nut driver, or small crescent wrench for the feedpoint 10-24 nuts.
- C. A 5/16" nut driver for the cable clamps.
- D. Screwdriver to back-up the 10-24 feedpoint machine screws.
- E. Hand riveter, also called a "POP™", or blind riveter. These are available from the company, a local hardware store, or possibly your dealer where this antenna was purchased. This is used to secure the element sections together. Use the smallest nozzle (tip) for the 1/8" rivets.

## I. EF-180BV ASSEMBLY.

- \_\_\_ 00) **NOTE: this entire antenna has already been assembled at the factory. This is how the holes get drilled and how the sub-assemblies are made. This means that every piece will align properly, provided that they are being assembled in the right position.**
- \_\_\_ 00a) **It should never be necessary to drill a hole for a rivet, or bolt.**
- \_\_\_ 00b) **Each element is dis-assembled and separately bundled, so working with one element at a time is the best method. This will ensure that only the parts for a particular element are available for assembly at one time.**
- \_\_\_ 00c) **Please check the measurements and the element positions to double check us at the factory. It is rare that a marking mistake is made, but it can happen.**
- \_\_\_ 0) The antenna is tapered and the taper runs smaller towards the top. Each section slides into another and to ensure a nice fit, the larger one is crimped/swaged to reduce its size slightly. This means that one end of each section is crimped/swaged and the reduced size of one end can be clearly seen. Only the tip is not done in this manner, since it is the end of the antenna.
- \_\_\_ 0a) Please be sure that the non-crimped/swaged end goes into the crimped/swaged end of the larger piece.
- \_\_\_ 0b) If the rivet holes do not align, please check to be sure the section is oriented properly. It should not be necessary to drill any holes.
- \_\_\_ 0c) Thanks.
- \_\_\_ 1) Lay out the antenna assembly sections.
- \_\_\_ 2) Apply Noalox compound to each of the sections that will slip into another. This can be a thin coat, spread evenly along and around the portion that is inserted into the larger tubing.
- \_\_\_ 3) The EF-180BV is divided into two logical parts: the trunk, which is towards the center, and the tip, which is to the top. The tip is assembled first.
- \_\_\_ a) **NOTE: there are two different length rivets. The longer ones are used for the inward tip sections that go through thick material. Please refer to the drawings.**
- \_\_\_ 4) Starting at the far end of the tip, slide the tip into the next larger section and align the rivet holes.
- \_\_\_ b) Insert the supplied 1/8" rivets into all rivet holes. It is important to insert all the rivets before any are pulled; otherwise, there is a possibility that the other holes might not align properly. To lessen this possibility, the holes are drilled to the actual rivet size (1/8"), which makes for a tight alignment and snug hole. If at any time it becomes necessary to remove a rivet, use an 1/8" drill and use the hole at the center of the rivet as the hole guide. Even if the hole is enlarged, the closed-end rivets will fill in the hole when they are pulled.
- NOTE: the longer rivets are used for the thick-wall joints.**
- \_\_\_ b) Pull each rivet with the hand riveter. The mandrel of the rivet (the "shaft") is inserted into the riveter and the handles of the riveter are squeezed. Sometimes, a complete squeeze of the riveter will not "pop" the rivet and release the mandrel. If this occurs, release the pressure on the riveter and push it back down over the mandrel (which will now be sticking out farther).
- \_\_\_ c) Slip each section into the matching larger tubing, as in the prior step and secure with the rivets. By starting at the tip, managing the element is physically easier.

- \_\_\_\_\_ d) The first section (inboard) of the tip sections are placed over the outboard portion of the fiberglass insulator(s). They are secured using the 1/2" aluminum stud and 3/8" Ny-Loc nut. The flat portion of the stud is for a 7/16" open-end wrench to hold the stud in position. The stud should be positioned so that the cable is in a like position as the others already installed (going towards the center and the flat parallel to the element).
  - \_\_\_\_\_ d1) The fiberglass might already be attached to the inner-most tip section.
- \_\_\_\_\_ 5) Double check that the tip sections have been fully assembled.
  - \_\_\_\_\_ a) Double check that the lock nuts on the studs are secure.
  - \_\_\_\_\_ b) Double check that the tip looks like the drawings.
- \_\_\_\_\_ 6) The trunk section is assembled next.
  - \_\_\_\_\_ a) Please refer to the drawings as necessary.
  - \_\_\_\_\_ b) Match up the trunk sections to be sure the 1/4-20 holes align properly.
  - \_\_\_\_\_ c) Apply Noalox compound to each joint and carefully slide the sections together.
  - \_\_\_\_\_ d) Secure the sections using 1/4-20 bolts and Nyloc nuts.
    - \_\_\_\_\_ **Tighten ONLY enough to secure the nut.**
    - \_\_\_\_\_ **Do not deform the tubing.**
  - \_\_\_\_\_ e) If not already attached to the fiberglass base insulator, attach the bottom base section (about 18" long) to the fiberglass using the 10-24 stainless machine screw, split-lock washer and nut.
  - \_\_\_\_\_ f) Double check that the feedpoint screws are secure on the fiberglass base insulator:
    - \_\_\_\_\_ e1) At the bottom of the trunk section.
    - \_\_\_\_\_ e2) At the top of the short base section.
    - \_\_\_\_\_ e3) The additional flat washers, lock washers and nuts are used to secure the feedline.
- \_\_\_\_\_ 7) The trunk section is now joined with the tip section.
- \_\_\_\_\_ 8) Locate the tip and slide it over the fiberglass outer insulator.
  - \_\_\_\_\_ a) Align the tip so that its rivets are pointing in the same orientation as those of the trunk (these are down when installed).
  - \_\_\_\_\_ b) Place the 1/2" machined aluminum stud through the trunk section and secure using 9/16" and 7/16" open-end wrenches.
  - \_\_\_\_\_ c) The studs are positioned on opposite sides of the element (see drawings).
  - \_\_\_\_\_ d) Please check the stud alignment again. Thanks.

## II. Attaching the Linear Loading and the Center Spreader.

- \_\_\_\_\_ 1) The linear loading wires are insulated from the spreader by a length of non-conductive material, which is heavy, braided dacron. This dacron is attached to the spreader using an eye-bolt. The eye-bolt has a nut that is placed close to the eye and, after the eye-bolt is run through the spreader, a Ny-loc nut is placed on the threaded end of the eye-bolt. This Ny-loc allows adjustment of the eye-bolt length for tensioning of the loading wires and the nut closest to the eye is backed-down to the spreader as a stop. This will keep the eye-bolt secure on the spreader and it will not move around.
  - \_\_\_\_\_ a) Notice that there are two (2) dacron lengths with eye-bolts.

- \_\_\_\_\_ b) The dacron is attached to the eye-bolt using a double half-hitch knot and the other end has a loop made by a bowline knot. Both of these knots will not slip.
  - \_\_\_\_\_ c) Install the eye-bolts and dacron insulating loops on the spreader, with the eye-bolts pointing UP.
- \_\_\_\_\_ 2) The linear loading is attached next.
- \_\_\_\_\_ 3) Refer to the drawings and pictures to acquire a solid understanding of the loading circuit, as this circuit is unique.
- \_\_\_\_\_ 4) Locate the linear loading wires and tuning jumpers.
- \_\_\_\_\_ a) Notice that both (2) of the wires are the same length.
  - \_\_\_\_\_ b) This is for convenience and the excess wire will vary from location to location.
  - \_\_\_\_\_ c) If the wires are desired to be made shorter for esthetics, that is acceptable, as the excess wire passing through the loop at the end of the non-conductive length will not change the electrical characteristics of the antenna.
- \_\_\_\_\_ 5) Now we're ready..... **USE CAUTION WITH THE ALUM-O-WELD WIRE, AS IT HAS A MIND OF ITS OWN AND CAN CAUSE PERSONAL DAMAGE IF NOT HANDLED CAREFULLY. USE EYE PROTECTION.**
- \_\_\_\_\_ 6) Again, please be careful with this wire.
- \_\_\_\_\_ a) Move out to the 1/2" aluminum studs at the outer insulator.
  - \_\_\_\_\_ b) Loosen the 1/4-20 hex bolts that are started in the studs and back the nuts out.
  - \_\_\_\_\_ c) Slide one end of a loading wire through the small hole in the outer (closest to the tip) stud from the center of the element and have about 2" protruding out towards the element tip.
    - \_\_\_\_\_ c1) Bend the excess wire back around the stud to form a hook. This will keep the wire from sliding out of the stud.
  - \_\_\_\_\_ d) Tighten the hex bolt snugly onto the wire, crunching it and holding it securely.
  - \_\_\_\_\_ e) Tighten the nut that is between the hex bolt head and the stud so that it compresses the lock washer against the stud. This will keep the bolt from coming loose.
  - \_\_\_\_\_ f) If the stud rotates, use a 7/16" open-end wrench (the same one that is used on the hex bolt/nut) on the flat portion of the stud and realign it.
  - \_\_\_\_\_ g) Slide another loading wire through the inner-most stud from the center of the element and have about 1/2" protruding out towards the element tip.
  - \_\_\_\_\_ h) Secure the hex bolt in the stud as before.
- \_\_\_\_\_ 7) The antenna can now be erected and then the linear loading can be attached to the spreader.
- \_\_\_\_\_ 8) The 8' center spreader needs to be assembled, as it is shipped in two sections.
- \_\_\_\_\_ a) Locate the two spreader sections and slide them together.
  - \_\_\_\_\_ b) Rivet the spreader together using short rivets.
  - \_\_\_\_\_ c) Slide the spreader through the U-bolts on the spreader mounting plate.
  - \_\_\_\_\_ d) Center the spreader on the antenna.
  - \_\_\_\_\_ e) Align the spreader with the holes at the ends pointing UP.
  - \_\_\_\_\_ f) Tighten the U-bolts holding the spreader.
    - \_\_\_\_\_ f1) The U-bolts do not have to be overly tight.

### III. Attaching the EF-180BV and spreader to the mounting (plate).

- \_\_\_ 1) The antenna can be mounted in two ways:
  - \_\_\_ a) Dropping the antenna over a support tube.
  - \_\_\_ b) Attaching the antenna to a support tube using the mounting plate.
    - \_\_\_ b1) The mounting plate attaches to the base section, NOT the trunk section, and the support attaches to the other side of the mounting plate.
- \_\_\_ 2) If using the mounting plate, it has four (4) pairs of holes in it. Two pairs are for the 2" U-bolts and saddles for the base section mast and two are for support, which also uses 2" U-bolts and saddles.
- \_\_\_ 3) The spreader mounting plate is also attached to the base section using a pair of 2" U-bolts and saddles.
  - \_\_\_ a) Attach the plate below the fiberglass base insulator AND attach it to the aluminum base section.
  - \_\_\_ b) The 8' long center spreader attaches to this plate using the smaller U-bolts.
- \_\_\_ 4) **The antenna is now (assumed to be) vertical.**
- \_\_\_ 5) Locate the cable clamps.
  - \_\_\_ a) Slip two (2) 1/8" cable clamps over the free end of both cables and keep the clamps on the outside of the spreader (up, towards the tip). One clamp is for the cable itself and the other for the tuning jumper.
  - \_\_\_ b) Refer to the drawing to have a good picture of the loading construction.
  - \_\_\_ c) Slide one end of the linear loading cable through the loop at the end of the dacron insulating rope.
  - \_\_\_ d) Bring the free end back upwards and apply just enough tension to take up the slack in the cable.
  - \_\_\_ e) Pass the free end through the cable clamp that is already on the cable and closest to the spreader. The wire is now doubled back on itself.
  - \_\_\_ f) Place the cable clamp towards the free end of the wire and tighten the nuts on the cable clamp. This will now be forming a very flat loop of wire. It is not necessary to "crunch" these nuts. Tighten only enough so that the cable is visually compressed and physically secure.
  - \_\_\_ g) Follow this same procedure for the other loading wire.
  - \_\_\_ h) These cables, although very strong, are primarily electrical in the element and are not necessarily for structural reasons.
- \_\_\_ 11) Position and secure the tuning jumper as follows, with the studs on the opposite side of the element, as shown in the drawing.
  - \_\_\_ a) For a frequency of about 3.790 MHz, set the tuning jumpers about 20" up from the spreader, not from the end of the eye-bolt.
  - \_\_\_ b) The jumper is secured using the second cable clamps already on the loading cables.

### IV. Attaching feedline and match.

- \_\_\_ 1) Attach the feedline to the two 10-24 bolts at the center. The supplied round terminals should be used to make a good connection to the screws.

- \_\_\_\_\_ a) If a balun is used, such as a *Force 12 B-1*, AZTEC or W2DU, attach the leads to the screws as above and plug the feedline into the other end of the balun.
  - \_\_\_\_\_ a1) Make sure the leads to the balun will not short out to the mounting plate or other hardware and secure the balun to the mast.
- \_\_\_\_\_ b) If coax is used directly, split about 3" of the coax and solder the round terminals to the coax. Slip the terminals over the screws and secure with the ny-loc nuts. Wind the coax into an RF choke by making at least 10 turns of about 10" diameter and tape or otherwise bind the coil together so that it cannot come apart. Note that at this low frequency, this type of current choke is not always effective. Ferrite beads around the coax will enhance its effectiveness.
- \_\_\_\_\_ 2) Attach the radials to the lower (base section). Please make sure they are installed as symetrically as possible and elevated is the best.
- \_\_\_\_\_ 3) Attach the hairpin matching coil across the feed point using the 10-24 hardware.
  - \_\_\_\_\_ a) Initially set the spacing between turns on the coil about 3/4".
- \_\_\_\_\_ 4) Check the antenna for resonance at the desired frequency.
  - \_\_\_\_\_ a) If the lowest VSWR is not 1:1, adjust the match by separating the turns on the coil, or by making them closer together.
- \_\_\_\_\_ 5) If the antenna is not on the desired frequency, readjust the tuning jumper as follows:
  - \_\_\_\_\_ a) Move the jumper upward to raise the frequency.
  - \_\_\_\_\_ b) Move the jumper down to lower the frequency.
  - \_\_\_\_\_ c) The spreader can be loosened so it can slide from side to side.
- \_\_\_\_\_ 6) Check the VSWR on other antennas in the area (i.e. on the mast) to be sure this antenna has not detuned them. If the VSWR has not changed, the interaction is minimal, but the front-to-back ratio of the other antenna(s) might have been lessened. This antenna can be mounted parallel to the other booms for the least interaction potential. It has been specifically designed for high reactance with other bands; however, coupling can still occur.

**V. FINAL CHECKOUT**

- \_\_\_\_\_ 1) Apply power and have fun.

*Notice.....*

***PLEASE BE CAREFUL AND DO NOT LET THIS ANTENNA COME INTO CONTACT WITH POWER LINES OR OTHER DANGERS. YOU CAN BE INJURED OR KILLED BY IMPROPER HANDLING OF THIS ANTENNA.***

***Thank you for selecting our product. We hope you enjoy using it.***

Force 12

# Elite Force EF-180BV

80/75 Meter C.I.C. Linear Loaded Vertical, ~35' long

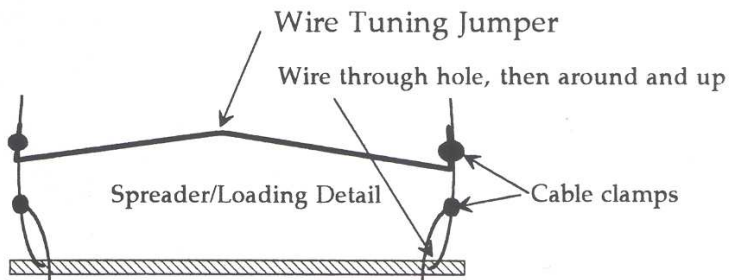
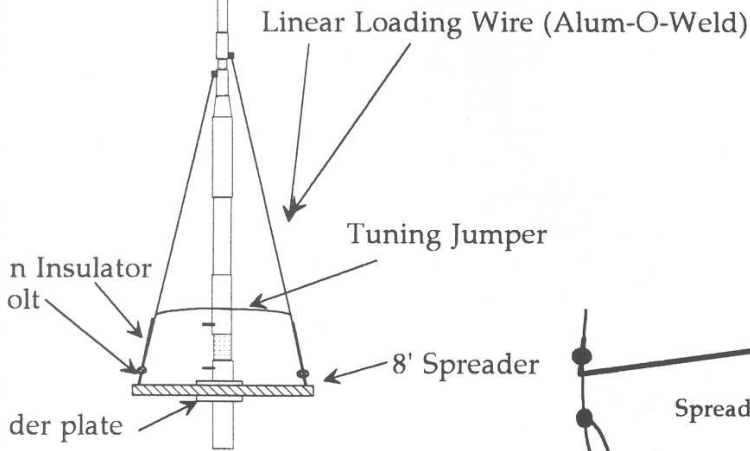
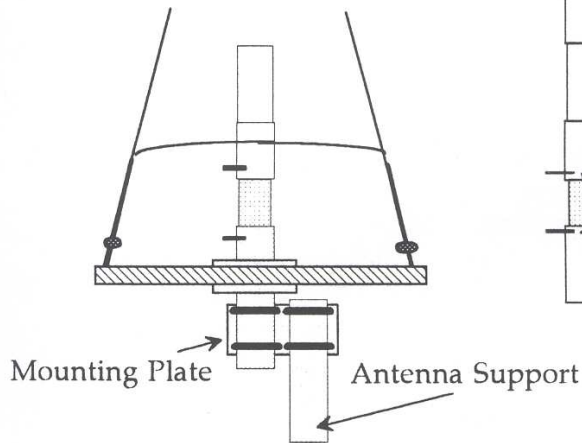
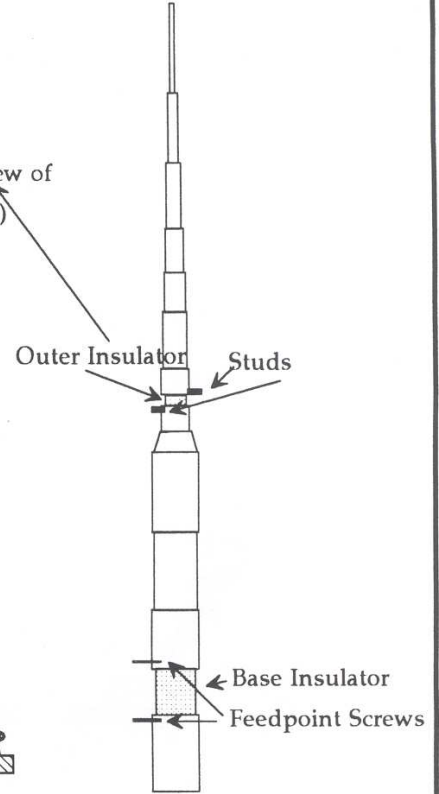
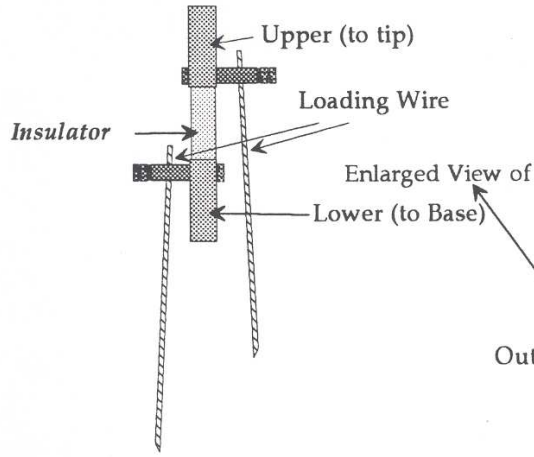
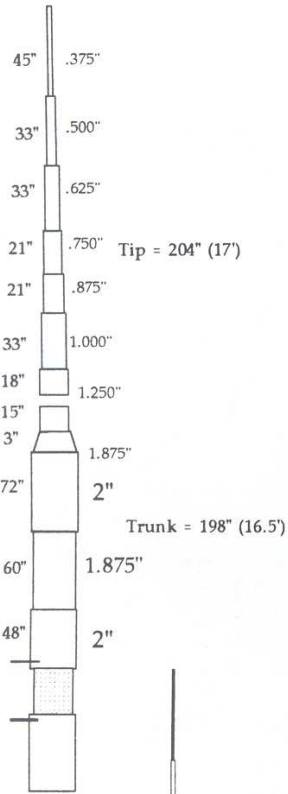

Copyright, BUY U.S.A., Inc, 1995,1996  
dw180bvn.001

NOT TO SCALE